

D1: _____ TOL: _____
 D2: _____ TOL: _____
 D3: _____ TOL: _____
 L1: _____
 L2: _____
 L3: _____
 L4 (CHAMFER LENGTH): _____
 A1 (CHAMFER ANGLE): _____
 A2 (STEP ANGLE): _____
 NO. FLUTES: _____
 SPIRAL (RH/LH/STR): _____
 CUT (RH/LH): _____
 HELIX ANGLE: _____
 END CUT STYLE: _____
 COATING: _____
 MAT'L BEING CUT: _____

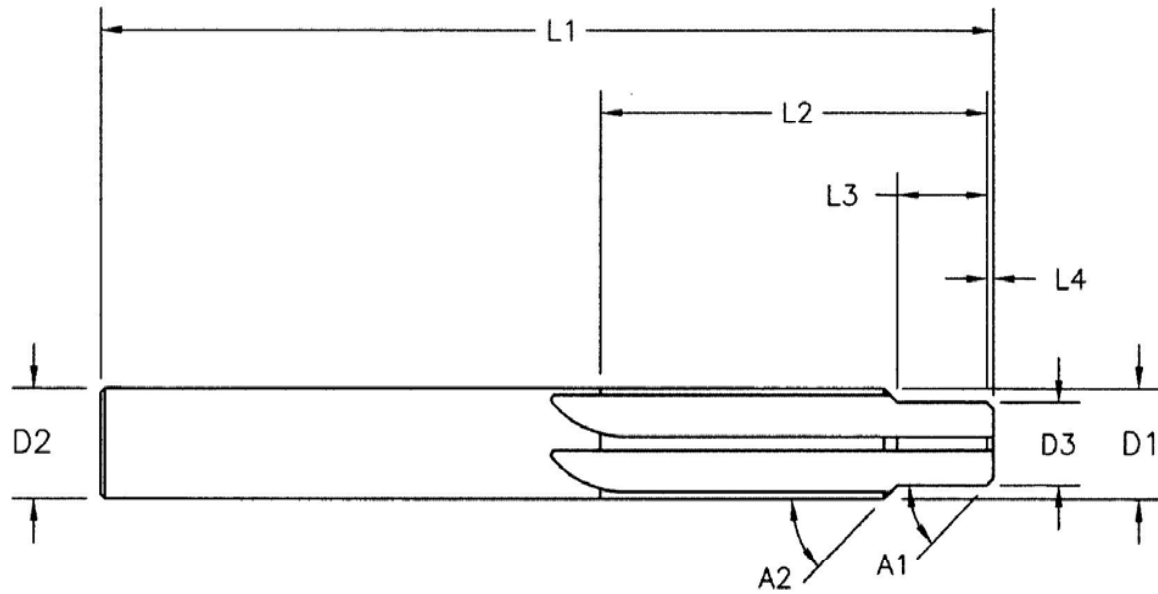

Superior Tool Service, Inc.
Industrial Tool & Cutter Grinding
Manufacturing & Resharpener
 3939 W Harry St., Wichita KS 67213
 Voice (316) 945-8488
 Fax (316) 945-8490
 Free (800) 428-8665

Piloted Reamer – Straight or Spiral Flute

REVISIONS
